



HA4AB Regulator with Electric Wide Opening

INTRODUCTION

These advanced-design, strong-bodied, precision-manufactured MODULAR regulators are superior in their ability to overcome dirt and sticky oil during opening and tight closing. Models are available for nearly every control function requirement of industrial ammonia and commercial halocarbon refrigeration. These regulators are ideal for cold storage plants, poultry plants, meat packing, fish processing, freezers, ice plants, breweries, bottling plants, heat recovery units, petrochemical plants, pharmaceutical plants, supermarkets, and many others.

APPLICATIONS

- Evaporator Pressure Control
- Defrost Pressure Control
- Condensing Pressure Regulation
- Receiver Pressure Control
- Hot Gas Bypass Capacity Regulation
- Suction Pressure Control
- Air or Liquid Temperature Regulation
- Internal System Pressure Relief

Specifications, Applications, Service Instructions & Parts

HA4A MODULAR PRESSURE REGULATORS 3/4" THROUGH 6" PORT (20MM THROUGH 150MM)

Various Connection Styles and Sizes for Refrigerants

KEY FEATURES

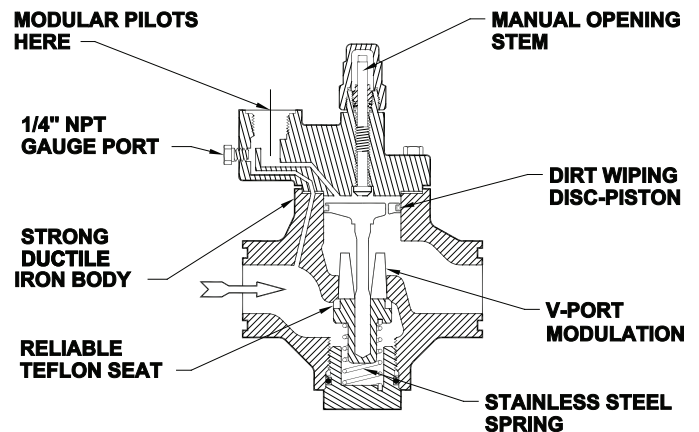

ADDITIONAL FEATURES

- Tolerant of Dry Systems
- For Ammonia, R22, R134a and other Hansen-Approved Refrigerants
- Wide Range of Options
- Inlet, Outlet, or Differential Pressure
- Wide Pressure Ranges
- Electric Shut-Off, Dual, or Wide-Opening Available
- Safe Working Pressure: 400 psig (28 bar g)
- CSA Certified, CRN for Canada
- Weld-In-Line Available; Contact Factory

Contents	Page
Regulator Variations	3
Capacities	4-5
Control Modules (Pilots)	6
Main Regulators Only (AR1, AR3)	7
Operation and Adjustment	8-11
Installation Dimensions	12-13
Parts List	14-18
Service and Maintenance, Abbreviations	19
Ordering Information, Conversions	20

MATERIAL SPECIFICATIONS

Body:

¾" through 4": Ductile iron, ASTM A536

5" & 6": Cast steel, ASTM A352 LCB

Adapter: Ductile iron, ASTM A536

Piston: Steel, disc type, Teflon piston seal

V-Port/Seat: ductile iron, with Teflon seat

Main Seat: ¾" through 1¼": integral ductile iron

1½" through 6": stainless steel, removable

Gaskets: Nonasbestos, graphite composite

Manual Opening Stem: Steel, plated

Pilots: Stainless steel trim

Pilot Orifice: Stainless steel

Flanges: Forged steel, ASTM A105

Safe Working Pressure: 400 psig (28 bar g), 600 PSIG
(41 bar g) available contact factory

Operating Temperature: -60°F to +240°F (-50°C to
+115°C)

ADVANTAGES

These valves combine modern design and new age materials with advanced manufacturing techniques and **intense** quality control to offer a significantly superior and reliable product. Their ductile iron bodies are stronger and more rugged than common cast iron, or so called semi-steel (class B iron), valves. They are more dirt resistant than full skirted-piston-design valves. All regulators use energized Teflon dirt-wiping piston seals which operate reliably, even under dry, oil-free conditions. The screw-on control modules (pilots) are easy to change and can be used on all valve sizes. All valves incorporate Teflon seating and stainless steel spring closing. Manual-opening stems are located on top of valves, up and away from dirt and rust particles to avoid thread jamming. Nonasbestos gaskets are standard. These standard regulator valves use the same flanges and spacing as R/S model A4A, except 1¼" (32mm). Special Hansen 1¼" 4-bolt regulators are available from stock to exactly replace R/S 1¼" A4A only.

SIZING

Proper regulator valve sizing is important for smooth operation and long, trouble-free life of the valve. Therefore, capacity of the regulator at both the maximum and minimum flow and **pressure drop** should be analyzed. Pressure regulators will operate satisfactorily to approximately 15% of the maximum capacity of valve based on the corresponding pressure drop. In extreme cases, downsizing or two smaller regulators in parallel are necessary. For pressure drops exceeding 45 psi (3.1 bar g), special construction may be required. Contact the factory.

INSTALLATION

Regulators should be protected from dirt and moisture during storage. The arrow on the body should be in the normal direction of refrigerant flow. *These valves will not prevent reverse flow*; use check valves where necessary. Regulators are normally in horizontal pipe lines with pilots and manual-opening stems on top. Do not rotate the position of the valve adapter or the valve will not operate.

The system should be free of dirt, weld slag, and rust particles. Regulators can be equipped with separate, close-coupled inlet strainers. No small, hidden, internal screens are used. Gauges and gauge valves should be installed on the inlet and outlet to help in system diagnosis. Because of the many regulator pilot combinations, during installation of a large job, the regulator nameplates should be checked against piping drawings to guarantee proper function for each location. Where pilot solenoid control modules are used, the nameplate coil voltage should be checked before wiring. Pipe sizing, anchoring, valve rating, system design, and other precautionary factors should be taken into consideration to ensure "liquid hammer" will not occur when the valve opens or closes.

The 5" and 6" valves are type HA4W with integral butt weld end only. These steel-bodied regulators are directly welded into the pipe line. During welding, the manual-opening stem should be opened downward several turns to protect the Teflon seat from weld heat.

Welds should be annealed as necessary in accordance with good practice. Painting of valves and welds is recommended for corrosion protection. Pipe covering, where applied, should have proper moisture barrier. Before putting valves into service, all pipe connections, valve seats, cover seals, and stem seals should be tested for leaks at pressure levels called for in appropriate codes.

ELECTRICAL

When the electric shut-off, wide-opening, or dual feature is supplied, a Hansen low-wattage, molded electrical coil is included. Standard coil voltages are 115V, 208/230V, or 24V at 50/60Hz. Other voltages available. The coil properly operates between 85% and 110% of the rated voltage. Coils should only be energized while on the pilot solenoid tube. Unless otherwise specified, the standard coil with a ½" fitting for conduit is supplied with valves.

A **watertight solenoid coil** with 18" (450 mm) long wire pigtail leads and a steel frame housing with a ½" conduit fitting is **standard**.

Optional **DIN Plug Coils** are for grounded cord connections and include the necessary DIN plug socket with gasket.

Hansen long life Beacon Pilot Lights are available. They incorporate a totally encapsulated, unique secondary wound coil and LED light in a compact disc. These pilot lights require no additional wiring.

Note: Beacon Pilot Lights are for AC voltage coils only.

REGULATOR VARIATIONS

HA4A STANDARD REGULATOR

This most common pressure regulator modulates to control evaporator pressure, condensing pressure, pressure in a vessel, or pressure in a portion of a system. It is frequently called an evaporator pressure regulator (EPR) or back pressure regulator. Opens on rising inlet pressure. See page 8. Shown with M3W pilot.

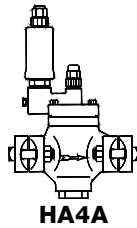

HA4A

HA4AS REGULATOR WITH ELECTRIC SHUT-OFF

This control is commonly used for temperature control or defrost. Regulates at the set-for pressure when energized. When de-energized, the valve closes tight regardless of the pressure setting. See page 9.

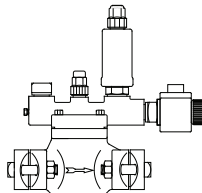

HA4AS

HA4AB REGULATOR WITH ELECTRIC WIDE OPENING

Commonly regulates for defrost or temperature, but opens wide for maximum cooling. Regulating at the set-for pressure when de-energized; regulator opens when energized. See page 9.

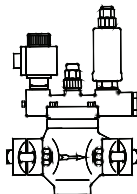

HA4AB

HA4AD DUAL PRESSURE REGULATOR

Regulates (evaporator) pressure at a setting when energized, and at a higher setting for defrost, temperature control, or pressure relief when de-energized. See page 9.

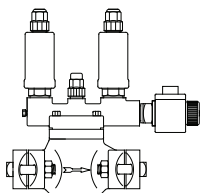

HA4AD

HA4AL DIFFERENTIAL PRESSURE REGULATOR

Commonly used as liquid pump relief, condenser-receiver pressure difference control, discharge pressure boosting for defrosting or heat recovery, and other similar applications. This control modulates to maintain the set-for difference between inlet and outlet pressure. See page 8.

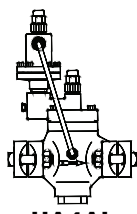

HA4AL

HA4AK RESEATING RELIEF REGULATOR

Used for defrost, high-to-low side relief, or nonatmosphere relief to other parts of the system. This control opens when system upstream pressure is above the tagged and sealed set point pressure, and repeatedly reseats after operation. See page 8.

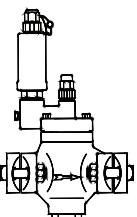

HA4AK

HA4AO OUTLET PRESSURE REGULATOR

Controls outlet pressure by opening as downstream pressure falls below the set point. Used for hot gas to provide artificial refrigeration loading, for condenser and receiver pressure control by means of gas bypass, limiting hot gas pressure supply in defrosting evaporator in conjunction with liquid drain traps, or for compressor suction pressure limitation. Can be combined with electric shut-off, temperature-operated, dual, or wide-opening features. See page 9.

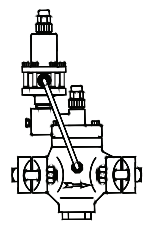

HA4AO

HA4AP PNEUMATICALLY COMPENSATED REGULATOR

Commonly used for precise air or liquid temperature control via pneumatic controller. An air, vapor, or liquid pressure signal to the control module bonnet increases inlet pressure from the set-for pressure value at a 1:1 ratio. See page 10.

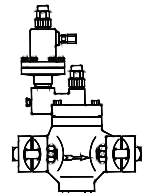

HA4AP

HA4AT TEMPERATURE OPERATED REGULATOR

The vapor pressure capillary tubing and bulb system modulates the regulator to open as temperature increases to control air or liquid temperature. See page 10.

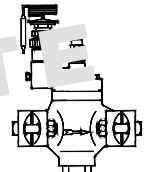

HA4AT

HA4AJ ELECTRONICALLY CONTROLLED REGULATOR

Electronic pilot and controller provides very precise temperature control of various control media under fluctuating load conditions. See page 10.

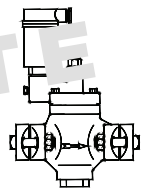

HA4AJ

HA4AM ELECTRIC MOTOR COMPENSATED REGULATOR

Commonly used for precise room temperature control or liquid chiller control. The controlling motor changes regulator pressure setting in accordance with a temperature controller. See page 11.

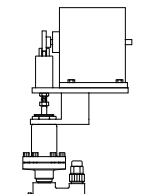

HA4AM

NOTE: Many other control functions can be achieved by combining the control modules in different arrangements. For example: a dual regulator with electric shut-off on each pressure pilot; i.e. HA4ADS.

SUCTION VAPOR CAPACITIES (TONS)
(1 Ton=12,000 Btu/hr=3.517 kW=3042 kcal/hr)

PORT SIZE (mm)	Cv (Kv)	PRESSURE DROP ACROSS VALVE‡	R717					R22				
			EVAPORATING TEMPERATURE					EVAPORATING TEMPERATURE				
			-40°F† (-40°C)	-20°F† (-28.9°C)	0°F (-17.8°C)	+20°F (-6.7°C)	+40°F (+4.4°C)	-40°F† (-40°C)	-20°F† (-28.9°C)	0°F (-17.8°C)	+20°F (-6.7°C)	+40°F (+4.4°C)
¾" (20)	6.4 (5.5)	2 psi	4.7	6.4	7.4	9.5	12	2.1	2.8	2.8	3.6	4.4
		5 psi	6.7	9.7	8.7	15	19	3.2	4.3	4.4	5.5	6.9
		10 psi	—	13	15	20	26	—	5.8	6.0	7.7	9.6
		20 psi	—	—	19	27	35	—	—	7.8	10	13
1" (25)	11.7 (10)	2 psi	8.5	12	13	17	22	3.9	5.2	5.2	6.5	8.0
		5 psi	12	18	16	27	34	5.8	7.9	8.0	10	13
		10 psi	—	23	28	37	47	—	11	11	14	18
		20 psi	—	—	36	49	64	—	—	14	19	24
1¼" (32)	16.4 (14)	2 psi	12	16	19	24	31	5.4	7.2	7.2	9.1	11.3
		5 psi	17	25	22	38	48	8.1	11	11	14	18
		10 psi	—	32	39	52	66	—	15	15	20	25
		20 psi	—	—	50	69	90	—	—	20	26	34
1½" (40)	35 (30)	2 psi	25	35	40	52	65	12	15	15	19	24
		5 psi	37	53	48	81	102	17	24	24	30	38
		10 psi	—	69	84	111	141	—	31	33	42	53
		20 psi	—	—	106	147	193	—	—	43	56	72
2" (50)	47 (40)	2 psi	34	47	54	70	87	16	21	21	26	32
		5 psi	49	71	64	108	137	23	32	32	41	51
		10 psi	—	92	113	149	190	—	42	44	56	71
		20 psi	—	—	143	198	259	—	—	57	76	96
2½" (65)	77 (66)	2 psi	56	77	89	114	143	25	34	34	43	53
		5 psi	81	116	105	177	224	38	52	53	67	83
		10 psi	—	151	185	243	311	—	69	72	92	116
		20 psi	—	—	234	324	424	—	—	94	124	158
3" (80)	104 (89)	2 psi	76	104	120	154	193	34	46	46	58	71
		5 psi	109	157	141	239	303	51	70	71	90	112
		10 psi	—	204	250	329	420	—	93	97	125	156
		20 psi	—	—	316	438	572	—	—	127	167	213
4" (100)	166 (142)	2 psi	121	166	191	246	309	55	73	73	92	114
		5 psi	174	251	226	382	483	82	112	114	144	179
		10 psi	—	325	398	525	671	—	149	155	199	249
		20 psi	—	—	505	699	913	—	—	203	267	340
5" (125)	242 (207)	2 psi	176	242	278	358	450	80	107	107	135	166
		5 psi	254	365	329	557	704	120	163	166	210	261
		10 psi	—	474	581	765	978	—	218	226	290	363
		20 psi	—	—	736	1019	1331	—	—	295	390	496
6" (150)	413 (354)	2 psi	300	412	475	611	768	136	182	183	230	283
		5 psi	434	624	562	950	1202	204	278	282	358	446
		10 psi	—	809	991	1305	1669	—	371	386	496	620
		20 psi	—	—	1256	1739	2272	—	—	504	665	847

‡ 2 psi= 0.14 bar g 5 psi= 0.35 bar g 10 psi= 0.69 bar g 20 psi= 1.38 bar g

*Optional 25% or 50% reduced capacity ¾" (20 mm) plugs are available for unusually low loads if requested.

† -40°F (-40°C) and -20°F (-28.9°C) capacities are based on a two stage system.

For liquid overfeed evaporator suction between normal 2:1 to 5:1 rate, add 20% to the evaporator load or use the next larger port size to accommodate liquid volume accompanying the suction gas and to reduce impact velocity.

Conditions: Capacities are based on the evaporator temperatures shown and +86°F (+30°C) liquid. R717: For each 10°F (5.6°C) lower liquid temperature, increase the above table capacity by 3%. R22: For each 10°F (5.6°C) lower liquid temperature, increase the above table capacity by 5%. To convert for R134a, multiply the R22 table values by 0.73 (accuracy within 8%). For other refrigerant capacities and suitability, contact the factory.

LIQUID CAPACITIES (U.S. GPM)

APPLICATION: REFRIGERANT PUMP RELIEF REGULATOR (HA4AL)

PORT SIZE (mm)	R717 ΔP=30 psi (2 bar g)	R22 ΔP=30 psi (2 bar g)
¾" (20)	45	30
1" (25)	82	56
1¼" (32)	114	78
1½" (40)	256	168
2" (50)	324	230
2½" (65)	553	377
3" (80)	733	505

Capacities assume no gas flashing. No capacity correction required for temperatures between -40°F (-40°C) and +40°F (+4.4°C).

OIL CAPACITIES (U.S. GPM)

APPLICATION: SCREW COMPRESSOR OIL PUMP RELIEF REGULATOR (HA4AL)

PORT SIZE (mm)	OIL ΔP=30 psi (2 bar g)
¾" (20)	48
1" (25)	87
1¼" (32)	122
1½" (40)	260
2" (50)	350
2½" (65)	574
3" (80)	775

Capacities based on oil with less than 300 SSU viscosity.

HOT GAS DEFROST NOMINAL VALVE SIZING CAPACITIES (DEFROSTING EVAPORATOR SIZE TONS)

REFRIG.	APPLICATION	PORT SIZE (mm)					
		¾" (20)	1" (25)	1¼" (32)	1½" (40)	2" (50)	2½" (65)
R717	Hot Gas Solenoid*	9 to 15	15 to 28	28 to 39	39 to 73	73 to 106	106 to 165
	Defrost Relief Regulator	17 to 24	24 to 45	45 to 60	60 to 96	96 to 140	140 to 225
R22	Hot Gas Solenoid*	6 to 8	8 to 15	15 to 20	20 to 32	32 to 47	47 to 75
	Defrost Relief Regulator	6 to 8	8 to 15	15 to 20	20 to 32	32 to 47	47 to 75

*Or an outlet pressure regulator with electric shut-off (HA4AOS).

Evaporator tons at 10°F (5.6°C) TD (temperature differential), valve capacities are conservative. These capacities can be modified up or down depending on type of evaporator, temperature, mass, frost thickness, defrosting time, etc. Typical for -20°F (-28.9°C) evaporator.

GAS CAPACITIES (TONS)*

(1 Ton=12,000 Btu/hr=3.517 kW=3042 kcal/hr)

SIZE (mm)	DISCHARGE GAS REGULATOR				HOT GAS BY-PASS TO SUCTION			
	R717		R22		R717		R22	
	+86°F (+30°C) CONDENSING +140°F (+60°C) DISCHARGE	+86°F (+30°C) CONDENSING +140°F (+60°C) DISCHARGE	+86°F (+30°C) CONDENSING +140°F (+60°C) DISCHARGE	+86°F (+30°C) CONDENSING +140°F (+60°C) DISCHARGE	+15°F (-9.4°C) CONDENSING +15°F (-9.4°C) DISCHARGE †	+86°F (+30°C) CONDENSING +140°F (+60°C) DISCHARGE	+15°F (-9.4°C) CONDENSING +15°F (-9.4°C) DISCHARGE †	+15°F (-9.4°C) CONDENSING +15°F (-9.4°C) DISCHARGE †
¾" ** (20)	17	27	6.1	9.5	88	27	32	12
1" (25)	31	49	11	17	160	49	58	22
1¼" (32)	44	69	16	24	224	68	81	31
1½" (40)	94	147	33	52	479	146	173	66
2" (50)	126	197	45	70	643	196	232	89
2½" (65)	206	323	73	115	1054	321	380	146
3" (80)	279	437	99	155	1424	434	513	197
4" (100)	445	698	158	241	Hot gas bypass capacities are based on above given temperatures. Liquid temperature is the same as condensing temperature. Evaporator temperature +40°F (+4.4°C) or less for +86°F (+30°C) condensing; -22°F (-30°C) evaporator for +15°F (-9.4°C) condensing.			
5" (125)	649	1017	230	361				
6" (150)	1108	1735	393	616				

† Bypass from intermediate pressure at saturation temperature to booster suction.

*These capacities are not for hot gas defrost relief. See the chart in the middle of this page.

**Optional 25% and 50% reduced capacity ¾" (20mm) plugs are available.

Discharge gas capacities are based on +15°F (+10°C) evaporator temperature.

CONTROL MODULES (PILOTS) FOR ANY REGULATOR

When installed, these control modules (pilots) enable the main regulator to perform different control functions (see page 3, Regulator Variations). Pilots are normally factory installed, but can be retrofitted or interchanged in the field. The nonrising stem can be adjusted by using a ¼" wrench. Catalog numbers are for the screw-on pilot module. Interchangeable with Danfoss PM Series, size permitting.

INLET PRESSURE

Opens as inlet pressure rises. Range: A, 0 to 150 psig (0 to 10 bar g), Part 75-1097; Range B, 30 to 300 psig (2 to 21 bar g), Part 75-1098; Range C, 100 to 550 psig (6 to 38 bar g), Part 75-1204; Range D, 30 to 450 psig (2 to 31 bar g), Part 75-1205, or, Range V, 20" to 130 psig (-0.67 to +9 bar g), Part 75-1099. Catalog M3.

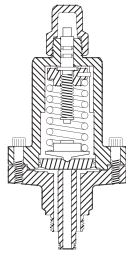

M3

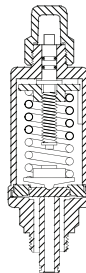

M3W

Compact welded pressure pilot. Range A, 0 to 150 psig (0 to 10 bar g), Part 75-1126. Standard only on valve sizes ¾" to 1¼". Catalog M3W.

OUTLET PRESSURE

Opens as outlet pressure drops. For hot gas bypass to suction or for controlled supply pressure of defrost hot gas. Also used for compressor suction pressure limiting (crankcase pressure regulator). ¼" NPT connections for outlet pressure gauge and sensing line (tubing not included). Range B, 30 to 300 psig (2 to 21 bar g), Part 75-1101; or Range V, 20" to 130 psig (-0.67 to +9 bar g), Part 75-1100. Catalog M3O.

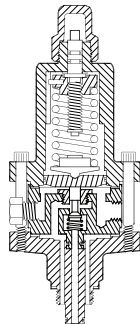

M3O

DIFFERENTIAL PRESSURE

Maintains set-for differential between inlet and outlet or other pressure source. For pump relief or any differential control. ¼" NPT connection for pressure sensing line (tubing not included). Range A, 0 to 150 psi (0 to 10 bar) difference, Part 75-1081, Catalog M3L.

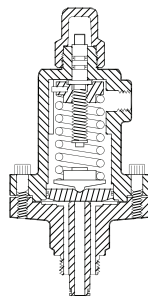

M3L

PNEUMATICALLY COMPENSATED

Air or other pressure in the bonnet raises inlet pressure on a 1:1 ratio. ¼" NPT connection. Range A, 0 to 150 psig (0 to 10 bar g), Part 75-1081, or Range V, 20 to 130 psig (-0.67 to 9 bar g), Part 75-1249. Catalog M3P.

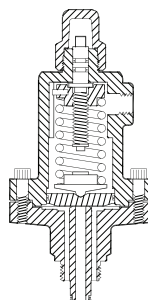

M3P

RESEATING RELIEF

Opens wide when pressure exceeds pressure setting and repeatedly reseats after operation. Defrost relief or high-to-low system relief. Set and tagged. The standard setting for ammonia defrost is 70 psig (4.8 bar g). Range A, 0 to 150 psig (0 to 10 bar g), Part 75-1103; Range B, 30 to 300 psig (+2 to 21 bar g), Part 75-1104; Range C, 100 to 550 psig (6 to 38 bar g), Part 75-1202; Range D, 30 to 450 psig (0 to 31 bar g), Part 75-1203. Catalog M3K.

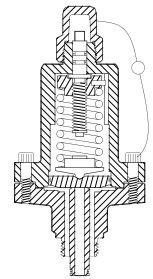

M3K

Compact welded pressure pilot. Range A, 0 to 150 psig (0 to 10 bar g), Part 75-1127. Standard on valve sizes ¾" to 1¼". Catalog M3KW.

SOLENOID

Normally closed. Opens wide when energized. Requires coil. See page 2 for coil selection. Less coil: Part 70-1052, Catalog MS.

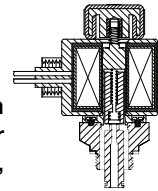

MS

ELECTRONICALLY CONTROLLED

Mounted electronic actuator changes the pressure set point in conjunction with a controller and temperature sensor for either air or liquid. Very precise. See page 10 for the control package which includes the necessary controller and sensor. Range: J1, 0 to 85 psig (0 to 6 bar g), Part 27B1140; or J2, 25 to 115 psig (1.7 to 8 bar g), Part 27B1141. Catalog M3J.

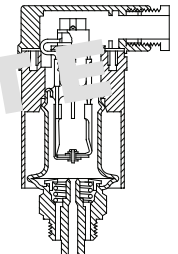

M3J

TEMPERATURE OPERATED

Bulb opens the control module on temperature rise to maintain a constant temperature. Part 27B1141 with a range of -10°F to +10°F (-40°C to 0°C) or Part 27B1141 with a range of +15°F to +75°F (-10 to +25°C). Catalog M3T.

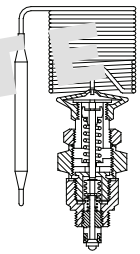

M3T

EXTERNAL CONNECTION

Enables a remote pressure source to be introduced to the control via a pilot line (replaces a pilot). ¼" NPT with separate 4" (100 mm) long weld nipple, Part 35-1015, Catalog M3E25.

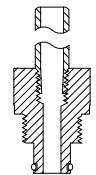

M3E25

BLANKING PLUGS

To be used in a control module port when the port is not utilized. Stopping plugs have square head and are marked with "0" (75-1063). Straight through flow plugs have a hex head and are marked with "1" (75-1064). Catalog M3S (stopping) or M3B (straight through).

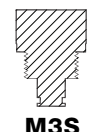

M3S



M3B

MAIN REGULATORS ONLY (AR1, AR3)

Hansen regulators are normally furnished with control modules (pilots) installed and tested (see page 3). However, modular regulators less pilots and flanges are available on order from 3/4" to 6" (20mm to 150mm). Each AR1 and AR3 includes flange gaskets, nuts and bolts, and a plugged 1/4" FPT outlet pressure access port. The access port is for connecting outlet or differential control module sensing lines or gauges.

AR1 is the main regulator body with ONE control module (pilot) port, control module not included.

AR3 is the main regulator body with THREE control module (pilot) ports, for a maximum of three control modules, not included. The 5" and 6" (125mm and 150mm) AR3 regulators have a single control module port with connection points for up to three total ports via mounted pilot piping.

TO ORDER: (Main Regulators only) Specify port size and catalog number (AR1 or AR3).

3/4" through 6"
(20 mm through
150 mm)

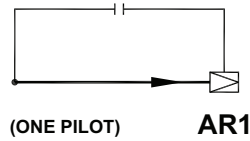

3/4" through 4"
(20 mm through
100 mm)

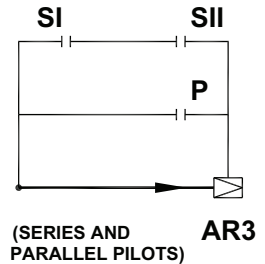

5" & 6"
(125 mm and 150 mm)

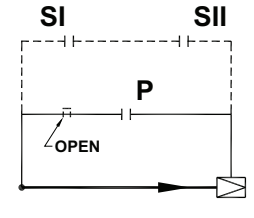
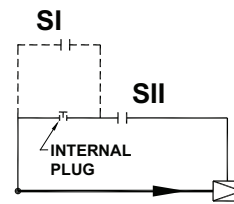

EXTERNAL PILOT PIPING

CONTROL MODULE
(PILOT) PORT

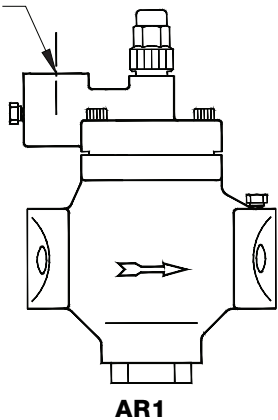

PARALLEL
PORT (P)

SERIES
PORT (SII)

SERIES
PORT (SI)

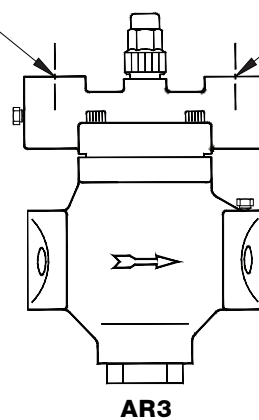

OPERATION OF REGULATORS

The regulator adapter (top cover) is available with one control module port or three control module ports. One control module port is often used for a solenoid valve or a single pressure regulator. Three control module ports are often used for a dual regulator and other multiple function variations.

When the modular regulator has three control module ports, two are in series (SI and SII) and one is in parallel (P). Inlet pressure enters the internal equalization passage and goes to both the P port and the SI port. Inlet pressure enters the SII when the control module SI port is open. When the control module in the SI and SII port or the P port is open, pressure enters the space above the piston which forces the main valve seat to open and regulate flow.

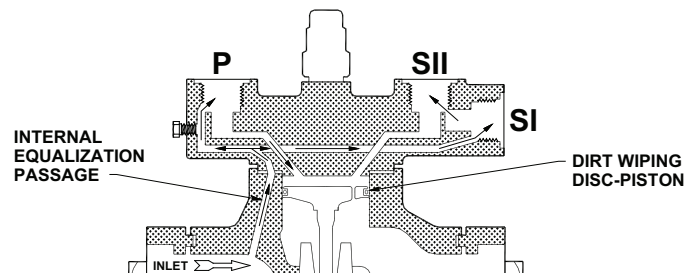

HA4A STANDARD REGULATOR

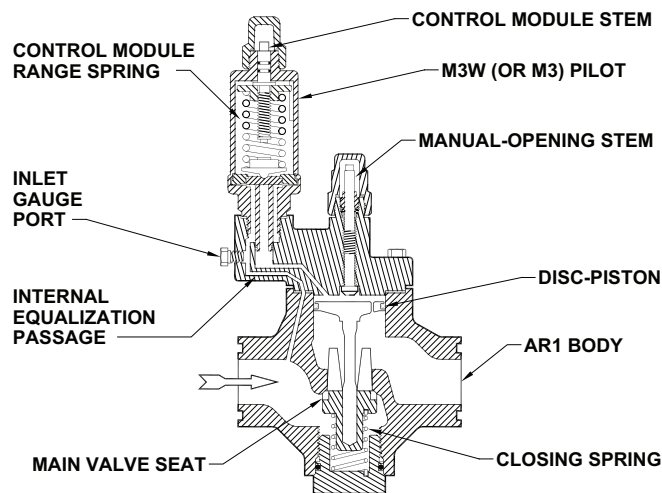

OPERATION

Inlet pressure is channeled through the internal equalization passage to the inlet pressure control module. The valve modulates open when inlet pressure exceeds the pressure setting on the control module. The gas or liquid passes through the inlet pressure control module to enter the space on top of the piston, which forces the main valve seat to open and regulate flow. As inlet pressure increases, the main valve seat opens further to maintain the selected inlet pressure. A minimum pressure difference of 2 psi (0.14 bar g) is adequate to fully open the main valve. When inlet pressure decreases below the pressure setting on the control module, the closing spring will cause the main valve seat to throttle closed.

ADJUSTMENT

Connect a pressure gauge via a gauge valve at the gauge port on the regulator adapter. Set the control module range spring at minimum force (control module stem turned counterclockwise). Operate the refrigeration compressor system and achieve approximate desired suction pressure. Turn the control module stem clockwise until a slight increase in inlet pressure is detected by the gauge. The inlet pressure setting can now be increased by turning the control module stem clockwise or decreased by turning it counterclockwise. The system should be allowed to operate for a period of time before the final adjustment is made. The inlet pressure control module is available in Range A, 0 to 150 psig (0 to 10 bar g); Range B, 30 to 300 psig (2 to 21 bar g); Range C, 100 to 550 psig (6 to 38 bar g), or Range D, 30 to 450 psig (2 to 31 bar g). A vacuum Range V, 20" to 130 psig (-0.67 to +9 bar g) is also available.

HA4AK RESEATING RELIEF REGULATOR

OPERATION

(Same as HA4A) Inlet pressure is channeled through the internal equalization passage to the reseating relief control module. When inlet pressure exceeds the relief setting, the control module opens wide to allow pressure to enter the space on top of the piston. This causes the main valve seat to open and relieve the inlet pressure, provided the outlet pressure is at least 2 psi (0.14 bar g) lower. A 5 psid (.35 bar g) closing spring is standard on 3/4" through 1 1/4" valves. See page 6 for M3K pilot details.

When used for defrost relief from low side to an intermediate pressure, a check valve on the outlet is required to prevent back flow during refrigeration.

ADJUSTMENT

The control module is nonadjustable, factory-set and sealed. Available in Range A, 0 to 150 psig (0 to 10 bar g); Range B, 30 to 300 psig (2 to 21 bar g); Range C, 100 to 550 psig (6 to 38 bar g), Range D, 30-450 psig (2 to 31 bar g).

HA4AL DIFFERENTIAL PRESSURE REGULATOR

OPERATION

Inlet pressure is channeled through the internal equalization passage to the differential pressure control module. Outlet pressure (or other) is introduced to the space on top of the differential pressure control module diaphragm via an external sensing tube. A range spring on the top of the control module diaphragm allows the control of the differential between inlet and outlet pressure. Increased range spring force increases the differential setting. Inlet pressure, counteracted by the range spring plus outlet pressure, enters the space on top of the piston which forces the main valve seat to open and regulate flow. The external sensing tube on the 5" & 6" valves must be customer supplied and field installed.

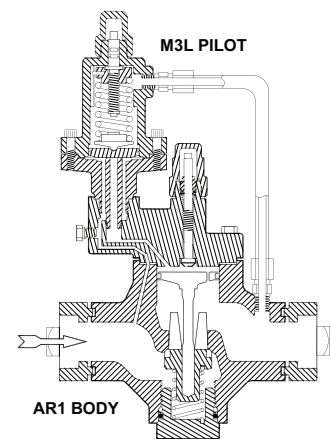

ADJUSTMENT

Connect a pressure gauge via a gauge valve at the gauge port on the regulator adapter for the inlet pressure reading. A pressure gauge downstream is also required. With the control module range spring force at the minimum (control module stem turned fully counterclockwise, at this point pressure differential is at minimum), slowly turn the control module stem clockwise until the desired pressure difference between the two gauges is achieved. A final adjustment should be made after system has operated for a period of time. The system must be capable of generating the desired pressure difference for the regulator to open. Range A, 0 to 150 psig (0 to 10 bar g).

HA4AO OUTLET PRESSURE REGULATOR

OPERATION

Outlet pressure is channeled through an external sensing tube to the outlet pressure control module. The outlet pressure is introduced to the space under the control module diaphragm. When outlet pressure decreases below the outlet pressure setting the range spring forces the control module to open further. As the control module opens, more inlet pressure enters the space on top of the piston forcing the main valve seat to open further and regulate flow. As outlet pressure rises the control module reduces the inlet pressure to the piston and the main valve seat starts closing. The external sensing tube on the 5" & 6" valves must be customer supplied and field installed. A 5 psid (.35 bar g) closing spring is standard on ¾" through 1¼" valves. A lighter spring is available for applications where a low pressure drop is required, such as holdback or crankcase pressure regulators.

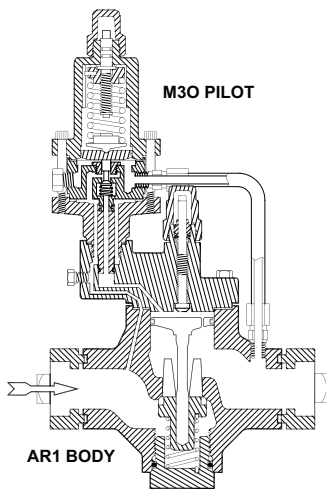

ADJUSTMENT

Connect a pressure gauge via a gauge valve to the outlet gauge port located on the outlet pressure control module or the pipe after the regulator. With the control module range spring at minimum force (control module stem turned counterclockwise) operate the refrigeration compressor. Turn the control module stem clockwise until the desired outlet pressure is achieved. Available in Range: B, 30 to 300 psig (2 to 21 bar g); or vacuum range V, 20" to 130 psig (-0.67 to +9 bar g).

HA4AB REGULATOR WITH ELECTRIC WIDE OPENING

OPERATION

When the solenoid control module is de-energized, this control operates in the same manner as the HA4A Standard Regulator or other pilot functions. When energized, inlet pressure bypasses the constant pressure control module and enters the space on top of the piston which forces the main valve seat to open wide to permit flow in the direction of arrow.

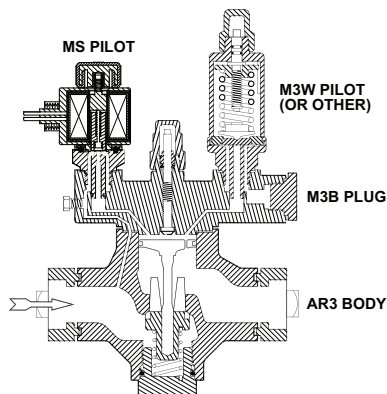

ADJUSTMENT

With solenoid control module de-energized, follow adjustment procedures for the HA4A Standard Regulator. See page 8.

HA4AS REGULATOR WITH ELECTRIC SHUT-OFF

OPERATION

When the solenoid control module is energized, this control operates in the same manner as the HA4A Standard Regulator or other pilot functions. When de-energized, valve closes tight to stop flow in direction of arrow regardless of pressure setting on the control module.

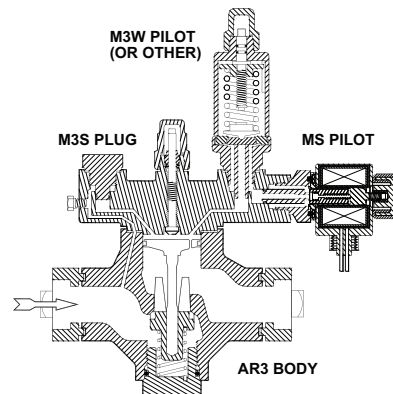

ADJUSTMENT

Energize the solenoid control module and follow the control module adjustment procedures for the HA4A Standard Regulator. See page 8.

HA4AD DUAL PRESSURE REGULATOR

OPERATION

When the solenoid control module is energized, this valve operates in the same manner as the HA4A Standard Regulator or other pilot functions. When the solenoid control module is de-energized, the inlet pressure is channeled to the higher-setting inlet pressure control module and operates in the same manner as the HA4A regulator. When inlet pressure rises above the higher setting, the control module opens to allow inlet pressure to enter the space on top of the piston which forces the main valve seat to open and regulate flow. Typically used as a combined evaporator pressure regulator and defrost internal relief valve.

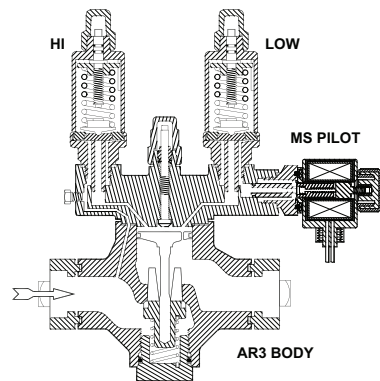

ADJUSTMENT

Connect a pressure gauge via a gauge valve at the gauge port on the regulator adapter. With the solenoid control module de-energized, adjust the constant pressure control module in the P port for the high-pressure setting. This may require a warm room or hot gas supply to the evaporator. Then, energize the solenoid control module located on the series SI port and adjust the constant pressure module in the series SII port for the low-pressure setting. For control module adjustment, follow the adjustment procedures for the HA4A Standard Regulator. See page 8.

HA4AP PNEUMATICALLY COMPENSATED REGULATOR

OPERATION

A pneumatic controller regulates the amount of air pressure applied to the top of the M3P control module diaphragm. A rise in temperature sensed by the pneumatic controller reduces the air pressure to the control module, allowing inlet pressure to enter the space on top of the piston which forces the main valve seat to open and regulate flow. A decrease in sensed temperature increases the pressure of air to the M3P control module. This increase in air pressure reduces the opening at the M3P control module and restricts the flow of inlet pressure to the piston, thus reducing the opening at the valve main seat. See page 6 for M3P pilot details.

ADJUSTMENT

Disconnect the air line to the M3P control module and follow the adjustment procedures for the HA4A Standard Regulator. See page 9. This sets the low inlet pressure setting for the regulator. Connect the air line back to the M3P control module. For every 1 psi (0.069 bar g) of increase in air pressure, the inlet refrigerant pressure setting increases 1 psi (0.069 bar g). Adjust the controller as specified by the manufacturer. In lieu of air, low-pressure refrigerant or other fluid can be used for compensation. The differential between inlet pressure and pressure to the M3P control module must not exceed 45 psi (3.1 bar g). Range A, 0 to 150 psig (0 to 10 bar g) or Range V, 20 to 130 psig (-0.67 to 9 bar g).

HA4AT TEMPERATURE OPERATED REGULATOR

OPERATION

Temperature changes are detected by the thermal bulb. The expansion or contraction of the charge inside the bulb and capillary tube is transferred across the diaphragm in the M3T control module. A rise in temperature above the set-for temperature opens the M3T control module and allows inlet pressure to enter the space on top of the piston which forces the main valve seat to open and regulate flow. A decrease in temperature closes the M3T control module which allows the piston to rise and close the main valve seat. A reverse acting model is also available: rising temperature closes the regulator, as for reheat. See page 6 for M3T pilot details.

ADJUSTMENT

Connect a pressure detector via a gauge valve at the gauge port on the regulator adapter. Place a thermometer in the cooled medium. With the system operating, set the M3T regulator control module to the desired temperature by turning the adjustment ring clockwise to lower opening temperature or counterclockwise to increase opening temperature. One turn is equivalent to a change of approximately 11°F (6.1°C). Tighten the locking ring after the adjustment has been made. Range -40°F to +30°F (-40°C to 0°C); or +15°F to +75°F (-10°C to +25°C).

HA4AJ ELECTRONICALLY CONTROLLED REGULATOR

OPERATION

The controller receives signals from an air or liquid sensor and transmits an electrical voltage to the M3J electronic actuator control module. An increase in temperature lowers the voltage to the actuator, opening the regulator to increase flow. A decrease in sensor temperature increases the voltage from the controller to the M3J electronic actuator control module closing the valve to reduce flow. This precision control can maintain temperatures within 1°F (0.5°C) of setting. The M3J electronic actuator control module *must* be operated by one of the control packages below. See page 6 for M3J pilot details.

CONTROL PACKAGES

- ECP** This standard electronic control package consists of a controller, controller base, sensor, and transformer.
- DDS** This control package includes the standard components plus a digital temperature readout, set-for/actual temperature switch. Easily check temperature, assembled and mounted on a metal back plate. To display the set-for temperature, simply depress and hold the set-for/actual temperature switch. When released, the digital readout will again display the actual temperature of the sensor.
- DDL** Same as the DDS with a minimum evaporator pressure adjustment. This adjustment sets an evaporator pressure “floor” independent of temperature. This is ideal to prevent too cold of an evaporator surface in bulk evaporators or during loading of critical, temperature-sensitive products.
- WTE2** Watertight controller enclosure for the above “DD” series control packages. This industrial-grade enclosure is polycarbonate with clear gasketed cover.
- EKA46** This computer interface is available for direct connection to the electronic actuator control module to a plant computer, PLC, or other controlling device. Input to interface is a regulated -20 mA or 0 to 10 volt signal from an intelligent control device. The EKA46 package includes interface module and transformer.

ADJUSTMENT

Set the desired temperature (REF) using both coarse and fine adjustments. Set the alarm limits (LIM) on deviation from the desired temperature, +1°C to +5°C. Adjust the alarm delay timer (DEL) to delay alarm release from 10 to 60 minutes. Both Proportional amplification (Kp) and Integration time (Tn) are factory set to 4. Consult the instruction manual or contact the factory if adjustment is necessary. See the instructions supplied with the EKA46 for its adjustment recommendations. M3J electronic actuator control module ranges: J1, 0 to 85 psig (0 to 6 bar g); or J2, 25 to 115 psig (1.7 to 8 bar g).

HA4AM ELECTRIC MOTOR COMPENSATED REGULATOR

OPERATION

The regulator pressure setting is altered as the motor receives a signal from a suitable temperature controller. The motor responds to maintain the balance in the electrical circuit. The rotation of the motor is transmitted through a cam, valve stem, and range spring to the top of the control module diaphragm. An increase in temperature decreases the range spring force on top of the control module diaphragm. This decrease in force on the diaphragm allows inlet pressure to pass through the control module to enter the space on top of the piston which forces the main valve seat open to reduce the evaporator pressure. A decrease in temperature causes an increase in the range spring force. This restricts the flow of inlet pressure to the piston causing a reduction in the opening of the main valve seat, reducing regulator flow by raising the pressure setting.

APPLICATIONS

This motor compensated regulator is popular for fruit storage, precision air temperature control, and liquid chiller control.

ADJUSTMENT

Adjust the temperature controller as specified by the manufacturer. Fully open the regulator manually by turning in (clockwise) the manual-opening stem to cool the product or room. Once the temperature at the sensing device is approximately as desired, adjust the controller output so that the cam is rotated to the center position. Put regulator back in automatic operation by turning the manual-opening stem out (counterclockwise). Loosen the adjustment locking nut. See the diagram to the right. Turn the adjustment stem clockwise to raise the inlet pressure setting or counterclockwise to lower the inlet pressure setting. When the desired refrigerant pressure setting is achieved, tighten the adjustment locking nut. A final adjustment should be made after the system has operated for a period of time.

Using a potentiometer slide wire type of controller (typically 135 ohm), depending on product heat load, a deviation from desired temperature of about +2°F to +5°F (+1.1°C to +2.8°C) is normal to rotate the regulator cam for maximum load satisfaction. As the load is reduced or as the temperature becomes lower, the cam rotates to create a higher evaporator pressure just adequate to balance the load and maintain the desired temperature, usually with ±1°F (0.5°C). Other controllers are available to operate the motor/cam rotation.

The basic Electric Motor Compensated Regulator consists of a nonremovable control module with a motor bracket and cam. The control module is available in either Range A, 0 to 150 psig (0 to +10 bar g); Range V, 20" to 130 psig (-0.67 to +9 bar g); or Range B, 30 to 300 psig (2 to 21 bar g). The motor bracket comes mounted on the control module and is suitable for use with any of the HONEYWELL motors. Two cams are available: Low Rise (standard) and High Rise. The table below indicates the pressure change possible for each cam.

RANGE	CAM	PRESSURE CHANGE
		HONEYWELL
A,B, or V	LOW RISE	30 psig (2.1 bar g)
	HIGH RISE	60 psig (4.1 bar g)

The HONEYWELL motor has 160° of rotation travel. Motors are available for either 135 ohm control signal input (24VAC Power input) or 4-20 mA control signal input (120V Power input). Electric proportional thermostat controllers (135 ohm output), electronic PID controllers (4-20 mA output) with sensor, and 24V transformers are available accessories.

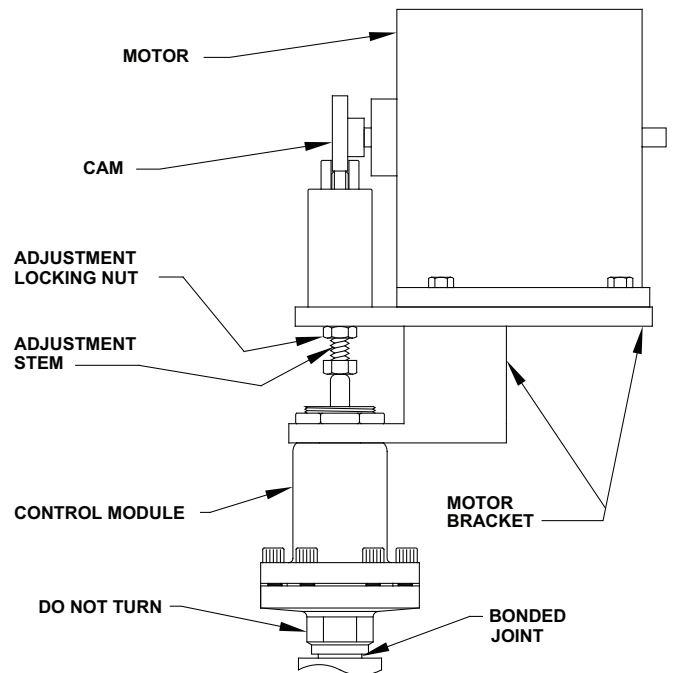

INSTALLATION DIMENSIONS (mm)

3/4" THROUGH 1 1/4" REGULATORS

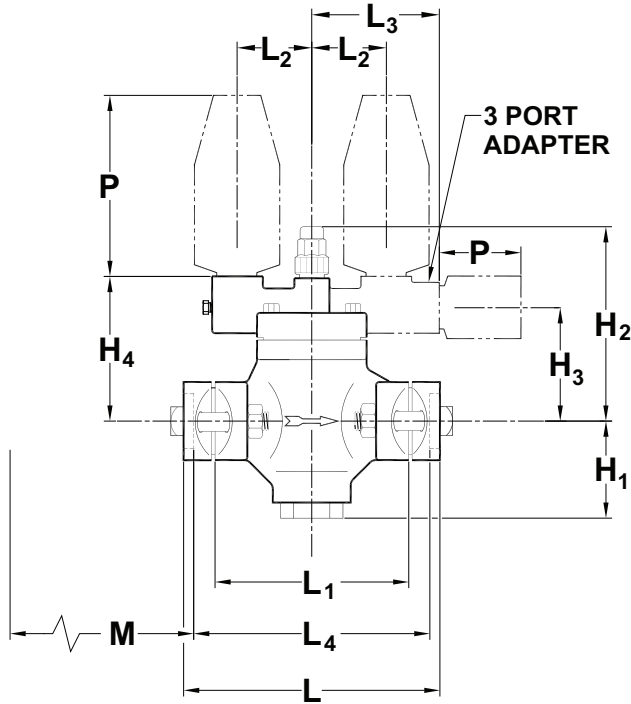

1 1/2" THROUGH 4" REGULATORS

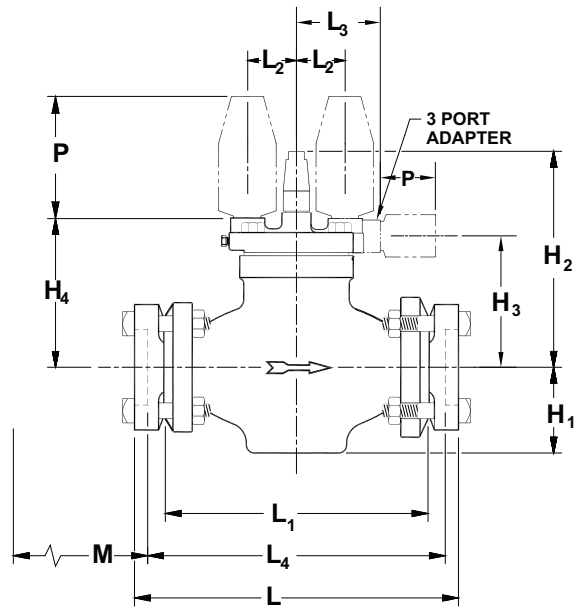

M = Additional length for close-coupled strainer

PORT SIZE (mm)	H ₁	H ₂	H ₃	H ₄	L		L ₁	L ₂	L ₃	L ₄	M	W*
					FPT,SW	WN,ODS						
3/4", 1", 1 1/4" (20, 25, 32)	3.09" (78)	6.77" (172)	3.75" (95)	4.63" (117)	8.20" (208)	8.94" (227)	6.19" (157)	2.38" (60)	4.07" (103)	7.20" (183)	3.70" (94)	4.50" (114)
1 1/2", 2" (40, 50)	2.87" (73)	8.84" (225)	4.90" (124)	5.72" (145)	12.39" (315)	13.39" (340)	9.88" (251)	2.35" (60)	4.04" (103)	10.89" (277)	9.83" (250)	4.50" (114)
2 1/2" (65)	3.62" (92)	9.69" (246)	5.57" (141)	6.53" (166)	13.01" (330)	14.03" (356)	9.88" (251)	2.35" (60)	4.04" (103)	11.01" (280)	9.83" (250)	5.62" (143)
3" (80)	4.06" (103)	10.00" (254)	6.03" (153)	6.88" (175)	15.38" (391)	16.40" (417)	12.25" (311)	2.35" (60)	4.04" (103)	13.38" (340)	12.20" (310)	6.50" (165)
4" (100)	4.69" (119)	10.56" (268)	6.58" (167)	7.46" (189)	17.01" (432)	20.51" (521)	14.12" (359)	2.69" (68)	4.38" (111)	15.01" (381)	14.07" (357)	8.06" (205)

*Maximum width of valve.

For 3/4", 1", 1 1/4" valves add 3" (80 mm) to one side of the valve for external piping as found on HA4AO and HA4AL.

An alternate 4-bolt version of the 1 1/4" valve is available with face-to-face dimension (L₁) same as R/S 1 1/4" for replacements.

"P" DIMENSION FOR CONTROL MODULES (mm)

CATALOG	M3	M3W	MS	M3O	M3K	M3KW	M3L	M3P	M3E25	M3M
SIZE (mm)	6.5" (165)	5.12" (130)	3.25" (83)	7.75" (197)	6.5" (165)	5.12" (130)	6.5" (165)	6.5" (165)	1" (25)	14.9" (378)

The above dimensions do not include seal cap and solenoid coil removal height, or motor-access clearance.

M3E25 = Less 4" (100mm) long weld nipple. M3M = Electric motor compensated control module with motor.

INSTALLATION DIMENSIONS (mm)

5" AND 6" REGULATORS

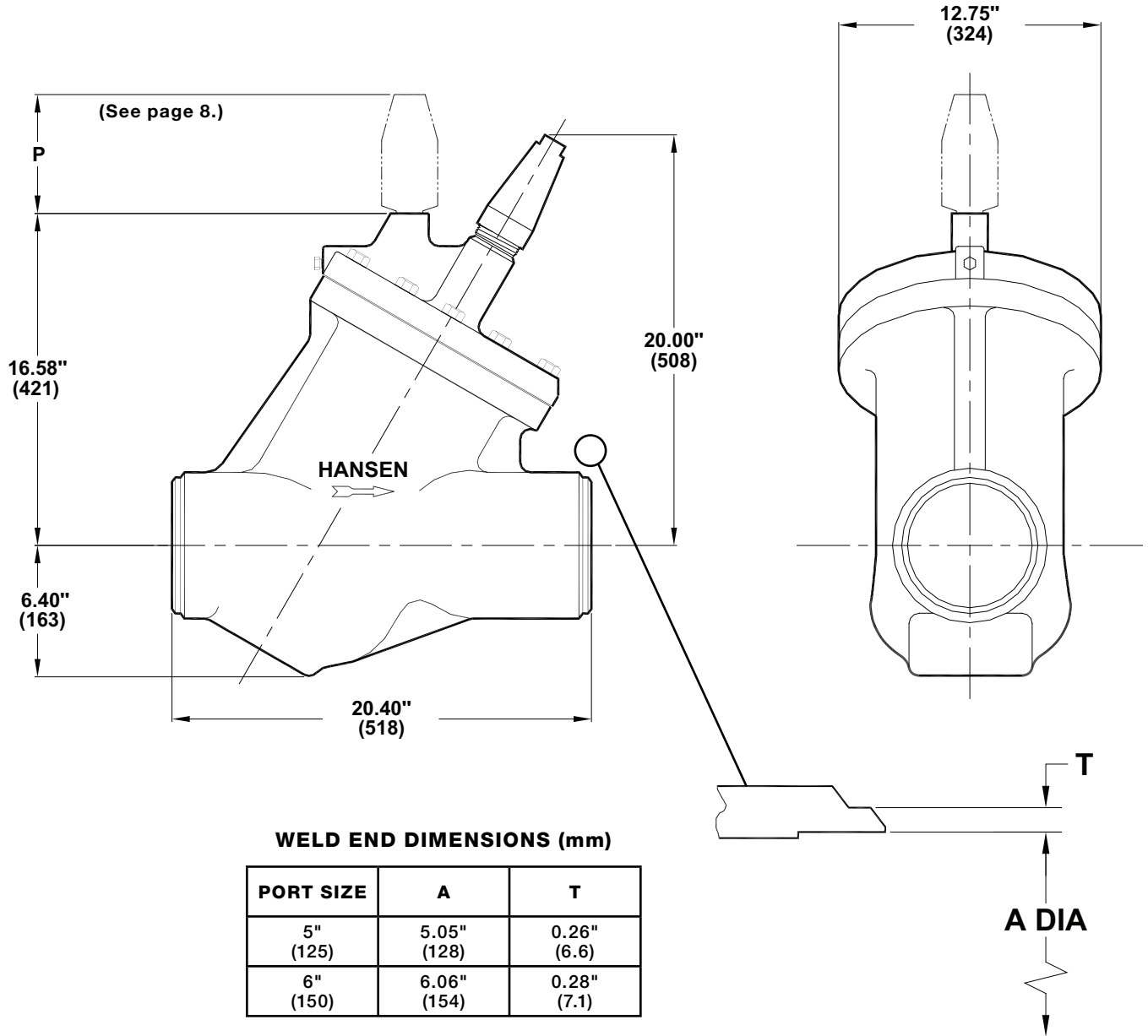

5" AND 6" PILOT PIPING (TOP VIEW)

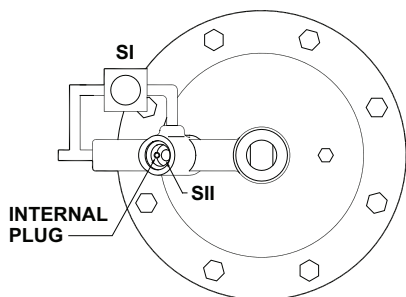

FOR SERIES ARRANGEMENT (AS)
SI, solenoid; SII pressure pilot

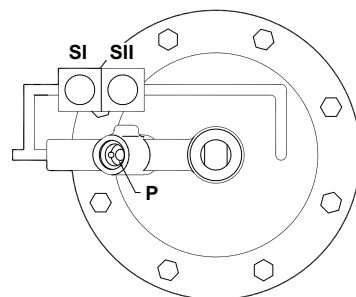

FOR SERIES AND PARALLEL ARRANGEMENT (AD)
SI, solenoid; SII & P pressure pilots

PARTS LIST CONTROL MODULES

M3, M3K, M3L, M3P

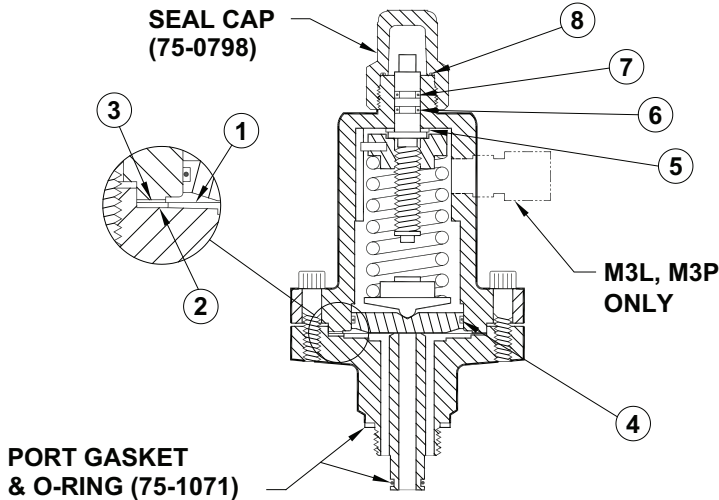

ITEM	DESCRIPTION	QTY	PART NO
	Diaphragm/Gasket Kit (M3, M3K, M3L, M3P)		75-1107
	<i>Above kit consists of:</i>		
1	Diaphragm	1	75-0716
2	Lower Gasket (thick)	1	75-0426
3	Upper Gasket (thin)	1	75-0636
4	Follower O-ring	1	75-0337
5	Fiber Washer	1	75-0617
6	Lower Stem O-ring (green dot)	1	75-0520
7	Upper Stem O-ring	1	75-0521
8	Seal Cap O-ring	1	70-0011

* M3W and M3KW control modules are hermetically sealed, welded assemblies having no replaceable internal parts. See page 6 for replacement part numbers. Standard on 3/4"-1 1/4" (20-32 mm) valves.

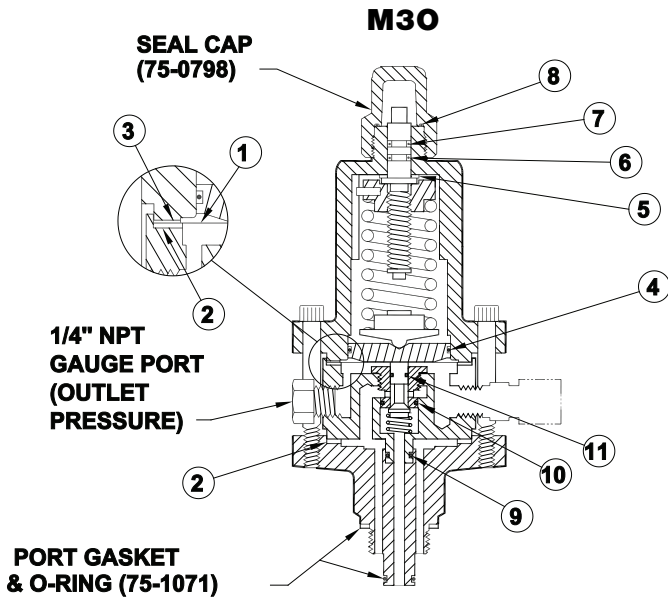

ITEM	DESCRIPTION	QTY	PART NO
	Diaphragm/Gasket Kit (M30)		75-1108
	<i>Above kit consists of:</i>		
1	Diaphragm	1	75-0716
2	Lower Gasket (thick)	2	75-0426
3	Upper Gasket (thin)	1	75-0636
4	Follower O-ring	1	75-0337
5	Fiber Washer	1	75-0617
6	Lower Stem O-ring (green dot)	1	75-0520
7	Upper Stem O-ring	1	75-0521
8	Seal Cap O-ring	1	70-0011
9	Cartridge O-ring	1	75-0496
10	O-Ring large, outlet pressure pilot	1	75-2316
11	O-Ring small, outlet pressure pilot	1	75-0419

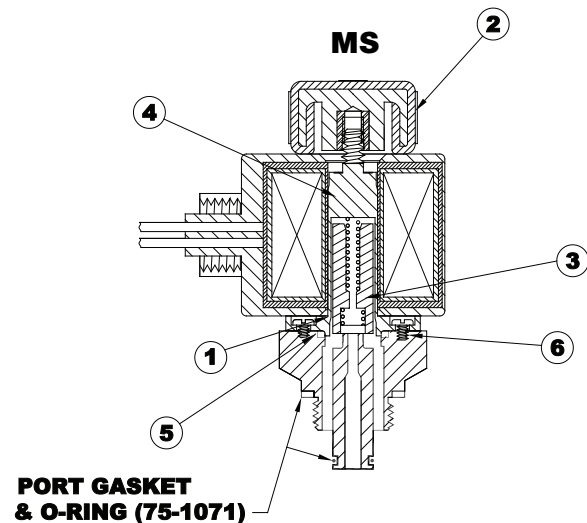

ITEM	DESCRIPTION	QTY	PART NO
	Solenoid Tube/Plunger Kit (MS)		70-1059
	<i>Above kit consists of:</i>		
1	Coil O-Ring	1	75-0340
2	Coil Knob	1	70-0579
3	Plunger	1	70-0295
4	Solenoid Tube	1	70-0298
5	Solenoid Tube O-Ring	1	72-0066
6	Tube Screws	4	70-0297

PARTS LIST 3/4" THROUGH 1 1/4" (20mm THROUGH 32mm)

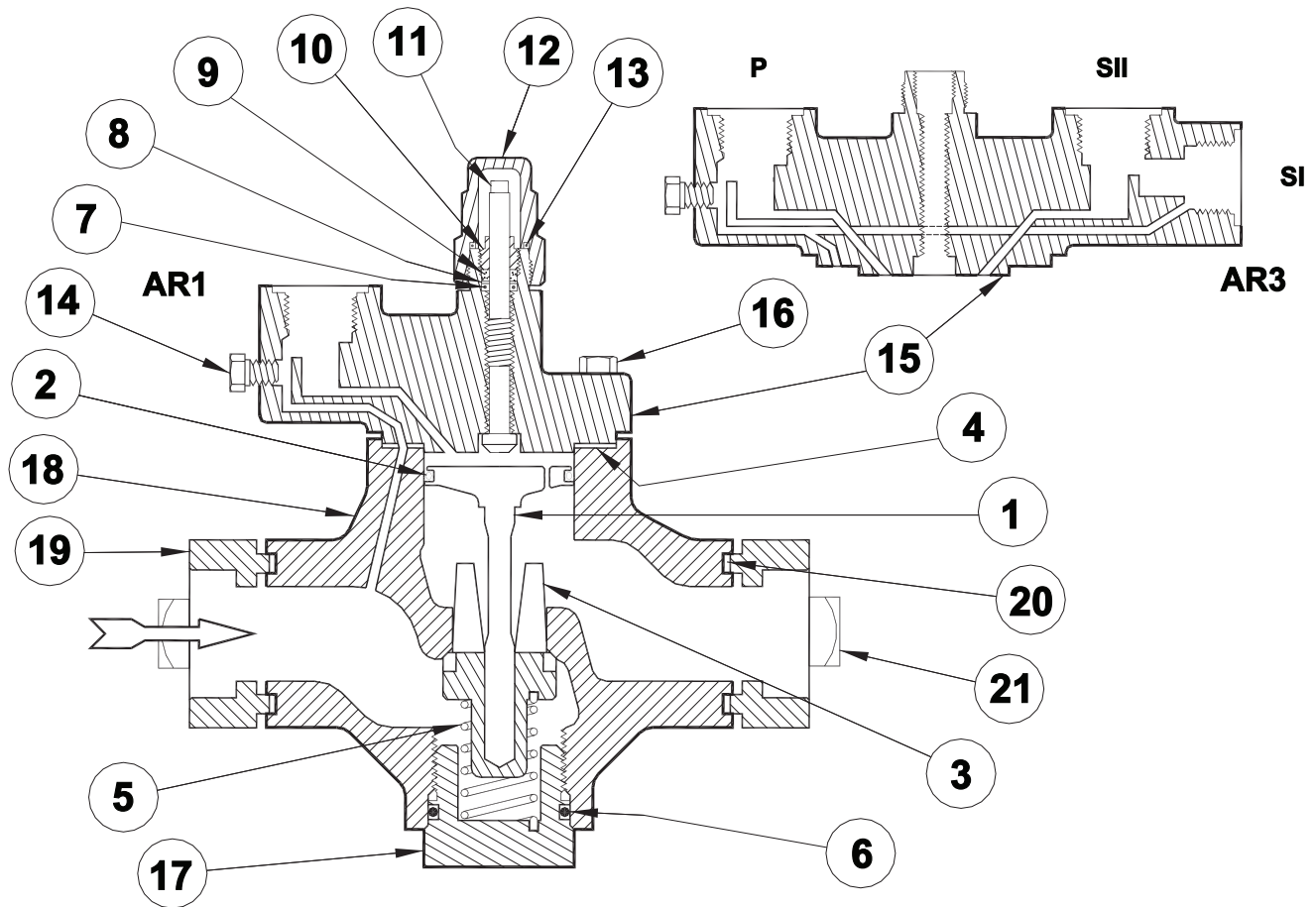

ITEM	DESCRIPTION	QTY	PART NO
	Piston Kit consists of:		75-1019
1	Piston	1	75-0191
2	Piston Seal	1	75-0353
4	Adapter Gasket	1	75-0489
20	Flange Gasket	2	70-0132
	V-Port/Seal Kit 3/4" *		75-1020
	V-Port/Seal Kit 1" *		75-1021
	V-Port/Seal Kit 1-1/4" *		75-1022
	<i>Above kits consist of:</i>		
3a	3/4" V-Port/Seat	1	75-0194
3b	1" V-Port/Seat	1	75-0193
3c	1-1/4" V-Port/Seat	1	75-0192
5	Closing Spring	1	75-0287
6	Bottom Cap O-ring	1	75-0183
4	Adapter Gasket	1	75-0489

ITEM	DESCRIPTION	QTY	PART NO
	Gasket Kit consists of:		75-1023
4	Adapter Gasket	1	75-0489
6	Bottom Cap O-ring	1	75-0183
7	Stem O-ring	1	70-0010
8	Stem Washer	1	70-0026
9	Stem Packing	1	70-0025
10	Packing Nut	1	70-0499
13	Seal Cap O-ring	1	70-0011
20	Flange Gasket	2	70-0132
	Solenoid Tube O-ring	1	72-0066
	Port Gasket & O-ring	3 EA	75-1071
11	Manual Opening Stem	1	75-0164
12	Seal Cap Kit	1	70-1042
14	Gauge Port Plug (1/4" NPT)	1	75-0189
15a	Adapter Kit*, 1 Port	1	75-1047
15b	Adapter Kit*, 3 Port	1	75-1048
16	Adapter Hex Screws (1/2"-13 x 1-1/2")	4	75-0190
17	Bottom Cap	1	75-0155
18	Body	1	FACTORY
19	Flange (Various)	2	FACTORY
21	Flange Bolt (5/8" - 11 x 2.75")	4	70-0339
	Flange Nut (5/8" - 11)	4	70-0136

*HA4AK AND HA4AO V-PORT/SEAT KITS	
DESCRIPTION	PART NO
V-Port/Seat Kit 3/4"	75-1129
V-Port/Seat Kit 1"	75-1130
V-Port/Seat Kit 1 1/4"	75-1131

Above kits contain V-Port/Seat, bottom cap O-ring, bonnet gasket, and a 5 psid (.35 bar) closing spring (Part 75-0622). A lighter spring is available (Part 75-0287).

* Adapter kit includes adapter, seal cap, manual open stem, gauge port plug, adapter gasket, stem packing, packing nut, and stem o-ring.

PARTS LIST 1½" THROUGH 4" (40mm THROUGH 100mm)

ITEM	DESCRIPTION	QTY	PART NO
	Piston Kit 1-1/2", 2"		75-1025
	Piston Kit 2-1/2"		75-1026
	Piston Kit 3"		75-1027
	Piston Kit 4"		75-1028
	<i>Above kits consist of:</i>		
1a	Piston 1-1/2", 2"	1	75-0957
1b	Piston 2-1/2"	1	75-2073
1c	Piston 3"	1	75-2072
1d	Piston 4"	1	75-0278
2a	Piston Seal 1-1/2", 2"	1	75-0292
2b	Piston Seal 2-1/2", 3"	1	75-0293
2c	Piston Seal 4"	1	75-0236
3a	Adapter Gasket 1-1/2", 2"	1	75-0113
3b	Adapter Gasket 2-1/2", 3"	1	75-0093
3c	Adapter Gasket 4"	1	75-0233
23a	Flange Gasket 1-1/2", 2"	2	75-0138
23b	Flange Gasket 2-1/2"	2	75-0125
23c	Flange Gasket 3"	2	75-0137
23d	Flange Gasket 4"	2	75-0253
	V-Port/Seat Kit 1-1/2"		75-1029
	V-Port/Seat Kit 2"		75-1030
	V-Port/Seat Kit 2-1/2"		75-1031
	V-Port/Seat Kit 3"		75-1032
	V-Port/Seat Kit 4"		75-1033
	<i>Above kits consist of:</i>		
4a	V-Port/Seat 1-1/2"	1	75-0369
4b	V-Port/Seat 2"	1	75-0177
4c	V-Port/Seat 2-1/2"	1	75-0178
4d	V-Port/Seat 3"	1	75-0179
4e	V-Port/Seat 4"	1	75-0313
3a	Adapter Gasket 1-1/2", 2"	1	75-0113
3b	Adapter Gasket 2-1/2", 3"	1	75-0093
3c	Adapter Gasket 4"	1	75-0233
6a	Seat Seal O-ring 1-1/2", 2"	1	75-0274
6b	Seat Seal O-ring 2-1/2"	1	75-0275
6c	Seat Seal O-ring 3", 4"	1	75-0276
7	Seat Screw	1	75-0220
8a	Closing Spring 1-1/2", 2"	1	75-0171
8b	Closing Spring 2-1/2"	1	75-0201
8c	Closing Spring 3"	1	75-0248
8d	Closing Spring 4"	1	75-0235
5a	Seat Ring 1-1/2", 2"	1	75-0084
5b	Seat Ring 2-1/2"	1	75-0170
5c	Seat Ring 3"	1	75-0071
5d	Seat Ring 4"	1	75-0231
16a	Manual Opening Stem 1-1/2" through 3"	1	75-0079
16b	Manual Opening Stem 4"	1	75-0427
17a	Seal Cap Kit 1-1/2" through 3"	1	75-1014
17b	Seal Cap Kit 4"	1	75-1015

ITEM	DESCRIPTION	QTY	PART NO
	Gasket Kit 1-1/2", 2"		75-1039
	Gasket Kit 2-1/2"		75-1040
	Gasket Kit 3"		75-1041
	Gasket Kit 4"		75-1042
	<i>Above kits consist of:</i>		
3a	Adapter Gasket 1-1/2", 2"	1	75-0113
3b	Adapter Gasket 2-1/2", 3"	1	75-0093
3c	Adapter Gasket 4"	1	75-0233
6a	Seat Seal O-ring 1-1/2", 2"	1	75-0274
6b	Seat Seal O-ring 2-1/2"	1	75-0275
6c	Seat Seal O-ring 3", 4"	1	75-0276
9a	Back-Up Washer 1-1/2" through 3"	1	75-0245
9b	Back-Up Washer 4"	1	50-0351
10a	Stem O-ring 1-1/2" through 3"	1	50-0179
10b	Stem O-ring 4"	1	50-0253
11a	Stem Washer 1-1/2" through 3"	1	50-0046
11b	Stem Washer 4"	1	50-0247
12a	Stem Packing 1-1/2" through 3"	1	50-0045
12b	Stem Packing 4"	1	50-0248
13a	Packing Nut 1-1/2" through 3"	1	50-0933
13b	Packing Nut 4"	1	50-0251
14a	Seal Cap O-ring 1-1/2" through 3"	1	50-0432
14b	Seal Cap Gasket 4"	1	50-0270
15a	Stem Pin 1-1/2" through 3"	1	75-0173
15b	Stem Pin 4"	1	75-0434
23a	Flange Gasket 1-1/2", 2"	2	75-0138
23b	Flange Gasket 2-1/2"	2	75-0125
23c	Flange Gasket 3"	2	75-0137
23d	Flange Gasket 4"	2	75-0253
	Solenoid Tube O-ring	1	72-0066
	Port O-ring and Gasket	3 EA	75-1071
18a	Adapter Kit*, 1 Port 1-1/2", 2"	1	75-1049
18b	Adapter Kit*, 3 Port 1-1/2", 2"	1	75-1050
18c	Adapter Kit*, 1 Port 2-1/2", 3"	1	75-1051
18d	Adapter Kit*, 3 Port 2-1/2", 3"	1	75-1052
18e	Adapter Kit*, 1 Port 4"	1	75-1053
18f	Adapter Kit*, 3 Port 4"	1	75-1114
19	Gauge Port Plug (1/4" NPT)	1	75-0189
20a	Adapter Hex Screws 1-1/2", 2" (1/2"-13 x 1-3/4")		75-0175
20b	Adapter Hex Screws 2-1/2", 3"(5/8"-11 x 2")	4	65-0057
20c	Adapter Hex Screws 4"(3/4"-10 x 2-1/2")	4	75-0291
21	Body	1	FACTORY
22	Flange (Various)	2	FACTORY
24a	Flange Bolt 1-1/2", 2" (5/8"-11 x 3.25")	8	70-0135
24b	Flange Bolt 2-1/2", 3" (3/4"-10 x 3.75")	8	75-0202
24c	Flange Bolt 4" (7/8"-9 x 4")	8	75-0279
25a	Flange Nut 1-1/2", 2", (5/8" - 11)	8	70-0136
25b	Flange Nut 2-1/2", 3", (3/4" - 10)	8	75-0210
25c	Flange Nut 4" (7/8" - 9)	8	75-0280

* Adapter kit includes adapter, seal cap, manual open stem, gauge port plug, adapter gasket, stem packing, packing nut, and stem o-ring.

PARTS LIST 1½" THROUGH 4" (40mm THROUGH 100mm)

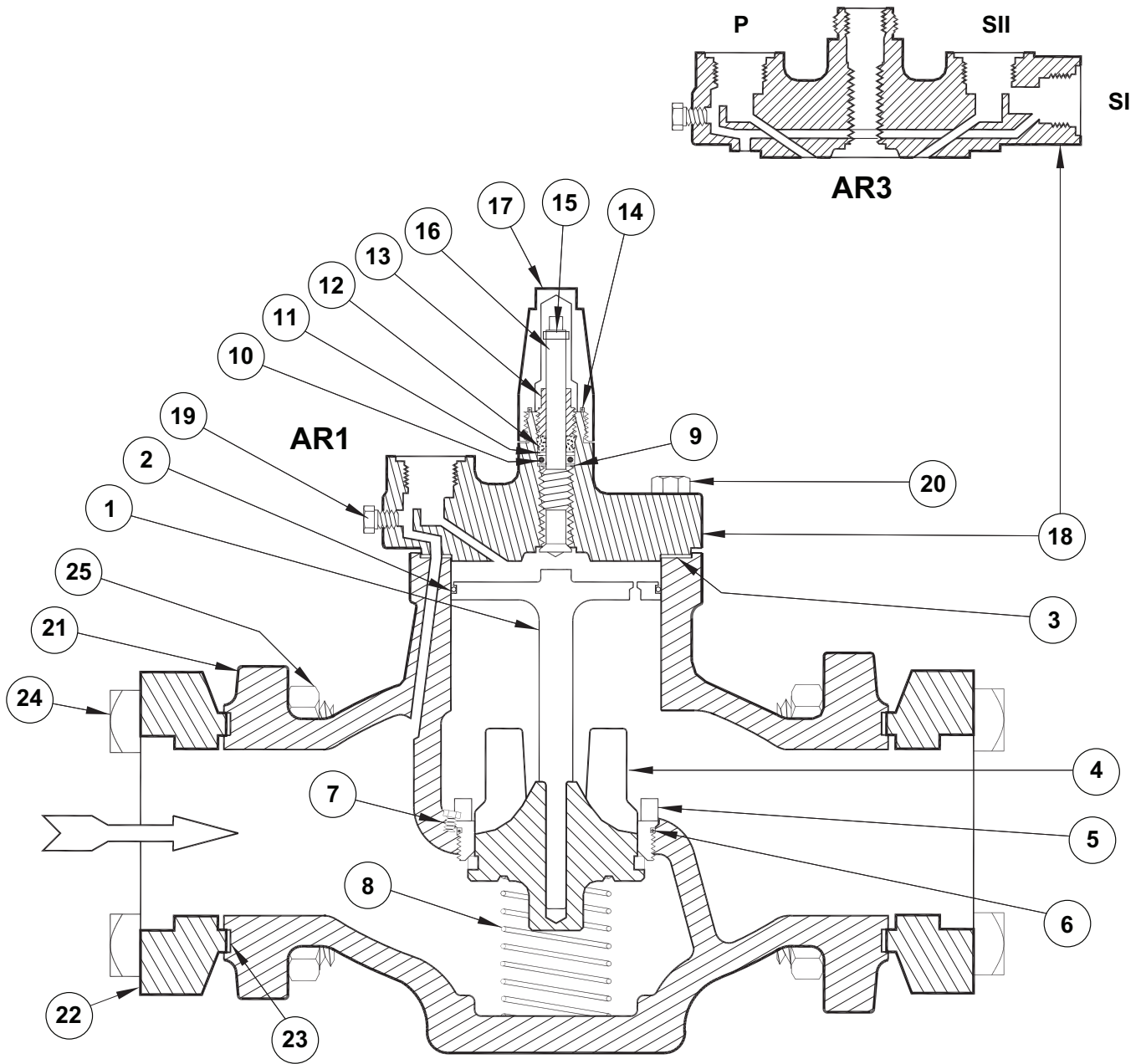

PARTS LIST 5" AND 6" (125mm AND 150mm)

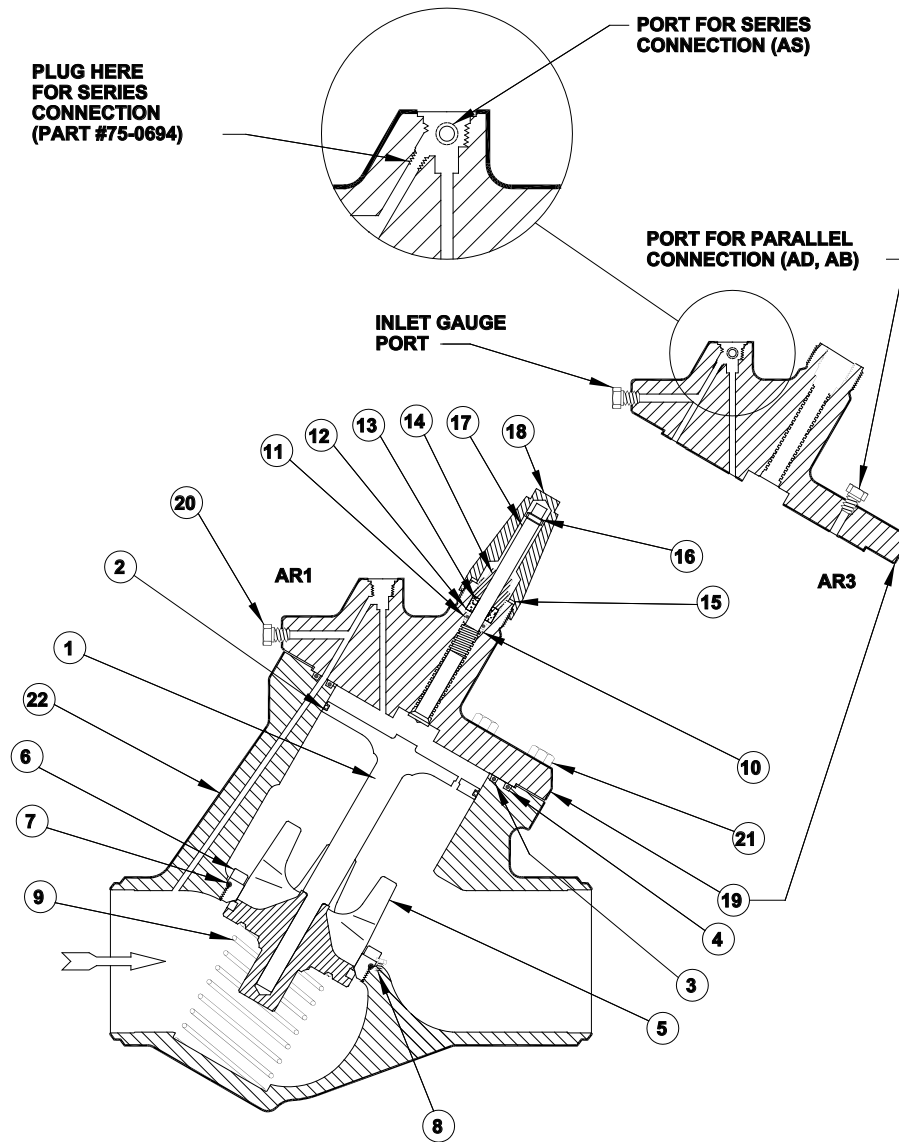

ITEM	DESCRIPTION	QTY	PART NO
	Piston Kit		75-1110
	<i>Above kit consists of:</i>		
1	Piston	1	75-0570
2	Piston Seal	1	75-0602
3	Adapter O-ring, Inner	1	75-0605
4	Adapter O-ring, Outer	1	75-0606
	Gasket Kit		75-1111
	<i>Above kit consist of:</i>		
3	Adapter O-ring, Inner	1	75-0605
4	Adapter O-ring, Outer	1	75-0606
7	Seat Seal O-ring	1	75-0613
10	Back-up Washer	1	50-0324
11	Stem O-ring	1	50-0293
12	Stem Washer	1	50-0299
13	Stem Packing	1	50-0290
14	Packing Nut	1	50-0292
15	Seal Cap Gasket	1	50-0315
16	Manual Opening Stem Pin	1	75-0607
	Solenoid Tube O-ring	1	72-0066
	Port O-ring and Gasket	3 EA	75-1071

ITEM	DESCRIPTION	QTY	PART NO
	V-Port/Seat Kit 5"		75-1112
	V-Port/Seat Kit 6"		75-1113
	<i>Above kits consist of:</i>		
5a	V-Port/Seat 5"	1	75-0640
5b	V-Port/Seat 6"	1	75-0641
3	Adapter O-ring, Inner	1	75-0605
4	Adapter O-ring, Outer	1	75-0606
7	Seat Seal O-ring	1	75-0613
8	Seat Screw (1/4" - 20x1/2")	1	75-0220
9	Closing Spring	1	75-0601
6	Seat Ring	1	75-0558
17	Manual Opening Stem	1	75-0581
18	Seal Cap Kit	1	50-1038
19	Adapter Kit*	1	75-1288
20	Gauge Port Plug	1	75-0189
21	Adapter Hex Screws 7/8"-9 x 3"	8	75-0604
22	Body	1	FACTORY

* Adapter kit includes adapter, seal cap, manual open stem, gauge port plug, adapter gasket, stem packing, packing nut, and stem o-ring.

SERVICE AND MAINTENANCE

Failure to open: Wrong coil or control module pilot; low line voltage; controlling switch or thermostat not contacting; coil is burned-out; adjacent shut-off valve closed; adapter gasket hole not aligned with hole in body and adapter; dirt packed under Teflon seal ring enabling excessive blow by; large quantity of dirt particles in solenoid module passages; dirt blocking internal pilot passages; main valve seat is dirt jammed.

Failure to close: Controlling switch or thermostat not opening contacts; manual-opening stem is turned in; valve installed in wrong direction; damage or dirt at main valve seat or pilot seat; piston bleed hole plugged. Under extreme conditions of liquid or oil "slugging" or pressure drops exceeding 45 psi (3.1 bar g), special construction may be required. Contact the factory.

Before opening the regulator or disassembling the pilot for service, be sure it is isolated from the system and all refrigerant is removed (pumped out to zero pressure). Follow usual refrigeration system safe servicing procedures. Read the CAUTION section of this bulletin on page 20.

To check solenoid pilot section of valve, disconnect the electrical coil. Unscrew the coil nut and remove washer. Lift coil housing away from valve. Remove the four solenoid tube screws and remove solenoid tube from valve. Inspect for dirt and damage to Teflon seat and stainless steel pilot orifice. Clean, polish or replace parts as necessary, then reassemble.

3/4" through 1 1/4" (20mm through 32mm): Use a 3/8" male hexagon wrench to loosen the four adapter bolts, proceeding slowly to avoid refrigerant which may still remain in the valve. If piston parts are stuck, remove the 2" hex bottom cap in order to separate the valve V-port/seat from the disc piston. Inspect disc and piston bore for burrs, nicks, and other damage. Remove burrs and nicks, clean or replace disc piston and Teflon seal ring as necessary. Long-life seal on disc piston need only be replaced when damaged or severely worn. If replacing the disc piston seal, make sure the seal is properly installed, with the edge up, and does not "twist" during installation. Inspect V-port/seat and main valve seat for nicks, marks, etc. The main valve seat may be lapped by hand or power drill to remove marks. Clean, polish or replace parts as necessary. If necessary, the V-port tapered seat may be reconditioned by removing up to 0.04" (1mm) of Teflon from it on a lathe. Lightly lubricate all parts and gaskets with soft rag containing refrigerant oil. Align hole in valve body, adapter gasket, and adapter to assure proper operation. Reassemble valve. Carefully check valve for leaks before returning it to service.

1 1/2" through 6" (40mm through 150mm): Loosen adapter bolts using a 12" adjustable wrench (15" wrench for 5" and 6" valves), being careful to avoid any refrigerant which may still remain in the valve. If disc piston is difficult to remove, insert a 1/4"-20 threaded screw (3/8"-16 for 5" & 6" valves) into center of piston and lift straight-up. Inspect piston and piston bore for burrs, nicks and other damage. Remove burrs and nicks, clean or replace piston as necessary. Long-life seal on disc piston need only be replaced when damaged or severely worn. If replacing the disc piston seal, make sure the seal is properly installed, with the edge up, and does

not "twist" during installation. These valves also have a removable stainless steel main valve seat. To remove seat ring for inspection, first remove small hex head seat screw. Turn the seat ring counterclockwise by turning it out with a wrench and a steel bar tool positioned horizontally or by carefully tapping the seat ring notch with a punch and a hammer. Inspect the V-port/seat and main valve seat for nicks, marks, and divots. The main valve seat may be lapped by hand or power drill to remove marks. Grease and replace the seat seal O-ring. Clean and polish, or replace the parts as necessary. If necessary, the V-port tapered seat may be reconditioned by removing up to 0.04" (1 mm) of Teflon from it on a lathe. Lightly lubricate all parts and gaskets with a soft rag containing refrigerant oil. Align the hole in the valve body, adapter gasket, and adapter to assure proper operation. Reassemble the valve. Carefully check the entire valve for leaks before restoring it to service.

MANUAL OPENING

The manual-opening stem is designed to open the valve, allowing upstream and downstream pressures to equalize when needed for servicing, but not necessarily to create a full-flow condition. The stem is located on the top of the adapter cover. Slowly remove the seal cap from the manual-opening stem, being cautious to avoid any refrigerant which may have collected under the cap. Using an appropriate wrench, turn the stem in (clockwise) to open the valve manually; counterclockwise to return the valve to automatic operation. Do not leave the stem partially open because it may be dynamically damaged.

ABBREVIATIONS

BW: Butt Weld end to match American Pipe Schedule 40

CRN: Canadian Registration Number

CSA: Canadian Standards Association

Cv: Valve capacity factor GPM (U.S.) of water at 1 psi differential

FPT: Female Pipe Thread, American National Standard

Kv: Valve capacity factor m³/hr of water at 1 bar g differential

mA: milliampere

MPT: Male Pipe Thread, American National Standard

NEMA: National Electrical Manufacturers Association: Class 4, watertight, approximate equivalent to IP65; Class 1, general purpose, approximate equivalent to IP20

NPT: National Pipe Thread

ODS: Outside Diameter Sweat, for copper tubing

PLC: Programmable Logic Controller

psig: Pounds per square inch, gauge

R/S: Refrigerating Specialties Division, Parker Hannifin Corp.

SPDT: Single Pole Double Throw

SW: Socket Weld to accommodate American and API pipe

WN or Weld: Weld Neck to match American Pipe Schedule 40

ORDERING INFORMATION, HA4A MODULAR PRESSURE REGULATORS

PORT SIZE (mm)	FLANGE CONNECTION STYLES & SIZES		
	FPT, SW, WN		ODS
	STD	ALSO	STD
†3/4" (20)	3/4"	1", 1¼"	7/8"
1" (25)	1"	¾", 1¼"	1⅛"
1¼" (32)	1¼"	¾", 1"	1⅜"
1½" (40)	1½"	2"	1⅝"
2" (50)	2"	1½"	2⅛"
2½" (65)	2½"	3"	2⅝"
3" (80)	3"	—	3⅛"
4" (100)	4"	—	4⅞"
5" (125)	5" BW	—	—
6" (150)	6" BW	—	—

5" & 6" are type HA4W with integral butt weld end only. 1¼" is standard 2-bolt flange design; 4-bolt flange style available upon request to field replace 1¼" R/S.

†25% and 50% Reduced Capacity Plugs are also available.

Weld-In-Line Available; contact Factory

TO ORDER: Specify type, connection style and size, range, voltage for coil, and close-coupled strainer if required. The strainer is a separate stainless steel 60 mesh unit which usually connects directly to the regulator inlet. Optional pilot lights are available in green, red, and amber. Please specify color and voltage when ordering the valve.

TYPICAL SPECIFICATIONS

"Refrigerant pressure regulators shall be pilot-operated, with disc-type pistons having Teflon seals, manual-opening stems, equipped with removable pilot modules, Teflon main seats and stainless steel pilot trim and optional, close-coupled inlet strainers, as manufactured by Hansen Technologies Corporation or approved equal."

OTHER PRODUCTS

Small Pressure Regulators and Reliefs
Gauge, Purge, and Needle Valves
Shut-Off Valves
Hand Expansion Valves (Regulators)
Refrigerant Solenoid Valves
Refrigerant Check Valves
Gas-Powered Valves
Refrigerant Float Switches
Float Drain Regulators
Refrigerant Liquid Pumps
AUTO-PURGER®s
Vari-Level® Adjustable Level Controls
Techni-Level® Transducer Probes
Frost Master® Defrost Controllers
Pressure-Relief Valves

REGULATOR ACCESSORIES

STRAINERS

Generous capacity, separate, close-coupled, 60 mesh (233 Micron Rating), accessible.

GAUGES

Pressure gauges have 3½" (90mm) diameter faces, safe plastic lenses, ¼" NPT connection, and recalibration features. Available for ammonia and halocarbon.

GAUGE VALVES

HGV1 "Long Neck" Gauge Valve, Seal Cap, ¼" MPT x FPT.

PILOT LIGHTS

Beacon Pilot Lights (green, red, or amber).

CONVERSIONS

1" (inch) = 25.4 m

$\Delta 1^\circ\text{F} = \Delta 5/9^\circ\text{C}$

Temperature in °F = 1.8°C + 32

Temperature in °C = $5/9$ (°F - 32)

1 psi = 0.06895 bar = 6.895 kPa

Cv (U.S. GPM) = Kv multiplied by 1.156

1 U.S. Gallon = 0.8327 Imperial Gallons = 3.7854 liters

1 U.S. GPM (gallons per minute) = 0.06309 dm³/s
(or L/s) = 0.227124 m³/hr

1 American Standard Commercial Ton of Refrigeration = 12000 Btu/h = 3024 kcal/h = 3.517 kW

CAUTION

Hansen valves are for refrigeration systems only. These instructions must be completely read and understood before selecting, using or servicing Hansen valves and electronics. Only knowledgeable, trained refrigeration mechanics should install, operate, or service. Stated temperature and pressure limits should not be exceeded. Bonnets, solenoid tubes, etc. should not be removed from valves unless system has been evacuated to zero pressure. See also Safety Precautions in the current List Price Schedule and the Safety Precautions Sheet supplied with the product.

WARRANTY

All Hansen products, except electronics, are guaranteed against defective materials or workmanship for one year F.O.B. factory. Electronics are guaranteed against defective materials or workmanship for 90 days F.O.B. factory. No consequential damages or field labor is included.

HANSEN

Hansen Technologies Corporation
400 Quadrangle Drive, Suite F
Bolingbrook, Illinois 60440 USA

Tel: 630.325.1565 Fax: 630.325.1572 Toll: 800.426.7368

Email: info@hantech.com Web: www.hantech.com

USA · Asia · Europe · India · Latin America · Middle East

© 2015 Hansen Technologies Corporation